

# NORTH AMERICAN ALBACORE CHAMPIONSHIP

Rehoboth Bay Sailing Association, Delaware USA

October 9-11, 2010

**Official Website: [http://usaa.albacore.org/north\\_americans](http://usaa.albacore.org/north_americans)**

## **SAILING INSTRUCTIONS**

### 1. RULES

1.1 This regatta is governed by The Racing Rules of Sailing (RRS) for 2009-2012, the prescriptions of the US Sailing Association, the 2004 Albacore Class Rules and any temporary rules or interpretations as published on [www.usaa.albacore.org](http://www.usaa.albacore.org), except as any of these is altered by these instructions or by the Notice of Race.

1.2 The regatta organizer will provide tracking devices (Garmin GPS72 or GPS76) for on-shore analysis of the racing. Each participating boat may elect to have the device installed for the regatta. The device read-outs must not be available to the boat's crew while on the water during the event. This modifies Albacore Class Rule 14.9.

### 2. ADVERTISING

Competitor advertising will be restricted as follows: Boats shall not display any Advertisement (ISAF regulation 20.6.4).

### 3. ENTRIES

Eligible boats may enter by completing registration with the regatta registration committee and presenting a valid measurement certificate to the committee in accordance with the NOR. Boats, sails or other equipment are subject to measurement at the discretion of the organizing authority. The helm of all boats shall be a full or associate member in good standing of a national Albacore association.

### 4. NOTICES TO COMPETITORS

Notices to competitors will be posted on the official notice board located the clubhouse of the Rehoboth Bay Sailing Association

### 5. CHANGES IN SAILING INSTRUCTIONS

Any change in the sailing instructions will be posted before 0900 on the notice board, except on Saturday, October 9-11, when changes will be posted within 10 minutes following the skippers' meeting.

### 6. SIGNALS

6.1 Signals made ashore are displayed on the club flagpole.

6.2 When "AP" (red and white vertical striped pennant) is displayed ashore '1 minute' is replaced with 'not less than 45 minutes.'

6.3 The departure signal is the raising of the RC flag on the Race Committee Boat with a sound signal, which will be at least 30 minutes before the first warning signal each day. This signal may be made after the Race Committee has departed the dock.

### 7. NUMBER AND SCHEDULE OF RACES

7.1 There is no maximum number of races scheduled for the North American Albacore Championship. Several races may be sailed on any day at the discretion of the race committee. The warning signal for the first race on each day is scheduled as indicated below.

|      |         |      |  |
|------|---------|------|--|
| Sat. | Oct. 9  | 1030 | Skippers Meeting   |
|      |         | 1200 | Warning for Race 1, Others may follow                            |
| Sun. | Oct. 10 | 1100 | Warning signal for the first race of the day. Others may follow. |

Mon. Oct. 11 1100 Warning signal for the first race of the day. Others may follow. Awards immediately following racing. No race will be started after 1400 on Monday Oct 11.

7.2 Races may be run back to back each day. "The display of Code Flag "H" (white and red vertical bars) at the finish of any race means "Racing has ended for the day."

## 8. THE COURSE

8.1 The diagrams in appendix A show the courses including the approximate angles between legs, the order to pass marks, and the side to leave each mark.

8.2 The T course is indicated by "T" and the O course by "O" displayed on a course board on the Race Committee Boat.

8.3 The finish mark may be offset from the course. Mark 1 is not a mark of the course on the final leg of the race.

## 9. MARKS

9.1 Appendix A describes Marks 1, 2 and 3.

9.2 Appendix A describes substitute marks, as required for RRS 33. If a second change of course is required then the second substitute mark will be as described in 9.1 and any further substitutions will continue alternating between the marks described in 9.1 and 9.2.

9.3 Appendix A describes the start and finishing marks.

## 10. THE START

10.1 The starting line is between a staff displaying an orange flag on a Race Committee boat (identified by its RC flag) and the start mark (as described in appendix A).

10.2 A boat shall not start later than 10 minutes after her starting signal.

## 11. RECALLS AND STARTING PENALTIES

11.1 The Race Committee will not attempt to hail boats that have started on course side.

NOTE: A Race Committee vessel may be in the vicinity of the start mark to aid in identifying premature starters.

11.2 The sail numbers of boats disqualified under the Black Flag Rule (30.3) will be displayed on a white board on the starboard side of the committee boat prior to the warning signal of a race to be restarted or resailed.

## 12. THE FINISH

The finishing line is between an orange flag on a Race Committee boat (identified by its RC flag or blue flag/shape flying) and the finish mark (as described in Appendix A).

## 13. TIME LIMIT

13.1 The time limit for the first yacht to finish is 2 hours from the starting signal for that fleet.

13.2 Boats failing to finish within 30 minutes after the first boat to finish are scored TLP (time limit penalty) as described in 15 Scoring, below. This changes rules 35, A4.1 and A4.2.

## 14. PROTESTS

14.1 In addition to the requirements of rule 61.1a, a boat intending to lodge a protest shall inform the Race Committee at the finishing line or as soon as practical thereafter.

14.2 The protest time limit is 60 minutes after the Race Committee comes ashore. Two sounds and the raising of the B flag (red with tail) signal the beginning of the 60-minute period. One sound and the lowering of the B flag signal the expiration of the 60-minute period.

14.3 A notice of protests filed and approximate hearing times will be posted on the Official Notice Board within 20 minutes of the end of protest time. Hearings will be held as soon as practicable following racing each day.

14.4 It is the responsibility of each boat to check the Official Notice Board to see if she has been cited in a protest. Failure of a boat to appear for a hearing will be considered grounds to proceed with the hearing under RRS 63.3(b)

## 15. SCORING

15.1 The low point scoring system described in RRS Appendix A applies except as modified in 15.1 through 15.5 below. This changes RRS Appendix A.

15.2 One complete race is required to constitute a series.

15.3 If five or fewer races are completed, a boat's series score is the total of all her race scores. Otherwise, her highest discardable point score is excluded.

15.4 A boat that starts correctly but fails to finish correctly (e.g., DNF, TLP) except any boat that is disqualified or retires after finishing (DSQ, RAF) shall be scored as follows. If there is one boat in this category for any race it shall be scored one (1) point more than the last boat to finish correctly. If there is more than one boat in this category, then they are all scored as if tied at the position behind the last boat to finish correctly and awarded the points for a tie in that position per RRS, Appendix A7

15.5 A boat which does not start correctly, retires after finishing or is disqualified, (e.g., DNC, DNS, BFD, OCS, DSQ, RAF, DNE, DGM) shall be awarded points equal to the number of boats in the start area at the start plus one (1). Boats that are disqualified under the black flag rule in a previous starting sequence for the same race shall be counted among the number of boats in the start area regardless of whether they remain in the start area for the actual start. If the count of boats in the start area is changed by protest, the change applies to all boats scored under 15.5.

## 16. SAFETY

16.1 Each boat shall pass astern of the Race Committee Boat on starboard tack and hail her sail number before starting each race so that her sail number can be recorded and acknowledged. Boats failing to do so are recorded as "Did Not Start". The Race Committee may fly the L flag (yellow and black squares) prior to the beginning of the starting sequence as a courtesy reminder for boats to check-in, but responsibility to check-in and obtain acknowledgement rests with the competitors regardless of whether or not the RC displays the L flag.

16.2 Sailors needing help should signal with an open hand. Those not needing help should signal with a closed fist.

16.3 A boat that retires from a race shall notify the Race Committee boat or a Race Committee vessel before leaving the course area, or, if that is impossible, notify the Race Committee or its representative immediately after arriving ashore.

16.4 Each boat must carry on board during the regatta a line suitable for towing not less than 30 ft. in length and not less than 1/4 inch in thickness.

## 17. CREW

No additions, deletions or substitutions shall be made during these events for any crew member without prior approval, in writing, of the organizing authority.

## APPENDIX A: COURSE DIAGRAMS AND MARKS

MARKS (9.1) : Marks 1, 2 and 3 are yellow cylinders.

SUBSTITUTE MARKS (9.2): New mark used for modification of course is an orange cylinder.

START MARK (10.2): is a yellow cylinder (also used as Mark 3 of the course)

FINISH MARK (12): is a red inflatable ball (tomato shaped).

COURSE T: Start – 1 – 2 – 3 – 1 – 2 – 3 – Finish (All marks of the course left to port)

COURSE O: Start – 1 – 2 – 3 -- 1 – 3 – Finish (All marks of the course left to port)

COURSE T

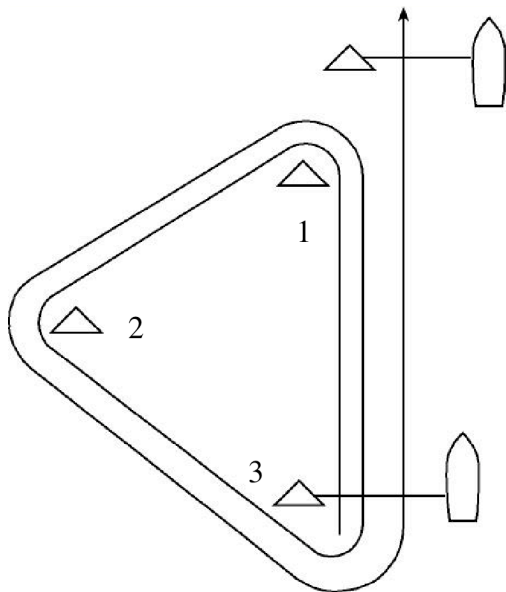

COURSE O

